

Service Manual

Flexible Disk Storage Drive
JU-455-5

Panasonic

Matsushita Communication
Industrial Co., Ltd.
Memory Systems Division
3-1, 4-chome, Tsunashima-Higashi
Kohoku-ku, Yokohama 223 JAPAN

CONTENTS

Page

PART I	
1.	INTRODUCTION 1
2.	MODELS AND MMODEL NUMBERS 1
3.	SPECIAL TOOLS 1
4.	OUTLINE OF MAINTENANCE 2
5.	DIAGNOSTIC PROCEDURES 2
5.1	Error Symptom Recognition 2
5.2	Soft Error Detection and Correction 2
5.3	Write Error 3
5.4	Read Error 3
5.5	Seek Error 3
5.6	Compatibility Error 3
6.	TROUBLE ANALYSIS 3
6.1	Trouble Analysis Procedure 3
6.2	Trouble Shooting 4
6.3	Trouble Analysis Table 5
7.	PREVENTIVE MAINTENANCE 5
8.	MEASUREMENT ITEMS FOR EACH MODEL 6
9.	ADJUSTMENTS AND VERIFICATIONS 7
9.1	Motor Speed Adjustment and Verification (Index Period) 7
9.2	Write Protect Verification 7
9.3	Head Output Verification 7
9.4	Output Modulation Verification 8
9.5	Radial Alignment Adjustment 8
9.6	Azimuth Verification 10
9.7	Index Burst Verifications 10
9.8	Track 00 Sensor Adjustment 11
9.9	Limiter Verifications (5.25-inch) 11
9.10	Limiter Adjustment (3.5-inch) 11
9.11	Asymmetry Verifications 11
10.	PANASONIC ALIGNMENT DISKETTE 12
PART II	
11.	REMOVALS AND INSTALLATIONS 13
11.1	PCB Removal and Installation 13
11.2	Front Plate Removal and Installation 13
11.3	Track 00 Assembly Removal and Installation 13
11.4	Collect Assembly Removal, Installation and Adjustment 14
11.5	Clamp Assembly Removal and Installation 14
11.6	Write Protect Sensor/Index Detector Assembly Removal and Installation 15
11.7	Cartridge Guide Assembly Removal and Installation 15
11.8	Stepper Motor Assembly Removal and Installation 16
11.9	Carriage Arm Assembly Removal and Installation 16
11.10	Drive Motor Removal and Installation 17
11.11	LED Assembly Removal and Installation 17
12.	TEST POINTS 18
13.	EXPLODED VIEW 19
14.	REPLACEMENT PARTS LIST 20
15.	REPLACEMENT PARTS LIST OF PCB 21
16.	SCHEMATIC DIAGRAM 22
17.	CIRCUIT BOARD 23
18.	BLOCK DIAGRAM 24

PART. I

1. INTRODUCTION

This service manual consists of two parts, Part I covering maintenance description, adjustment procedures, and trouble analysis and Part II disassembly and reassembly procedures parts list, and PCB circuits.

Part I encompasses maintenance instructions for all FDD models. Refer to the applicable items, and perform maintenance work on the FDD.

2. MODELS AND MODEL NUMBERS

2.1 5.25-inch FDD

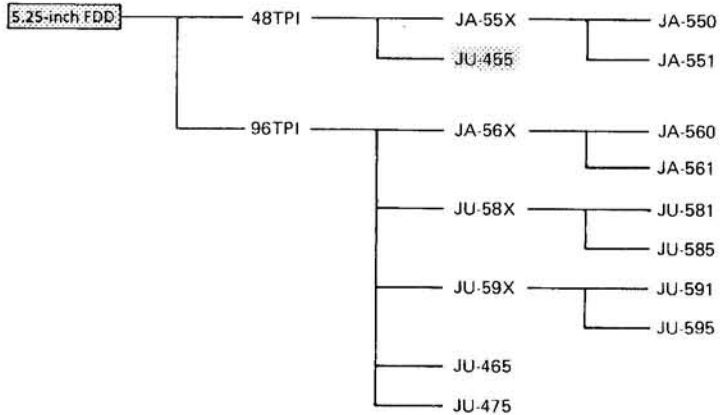

2.2 3.5-inch FDD

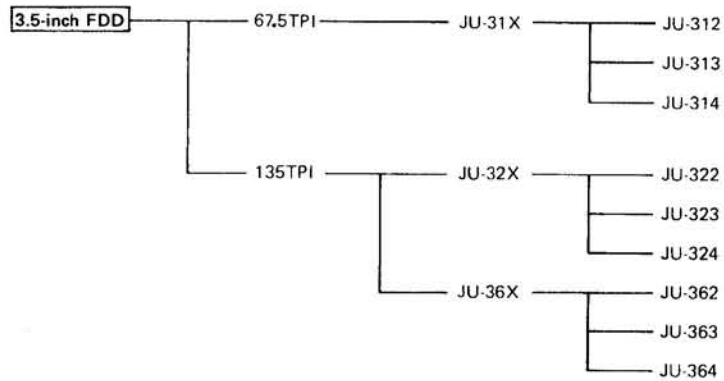

3. SPECIAL TOOLS

The following special tools are used for FDD maintenance.

TABLE 3.1

Tool	Part No.				Quantity
	5.25-inch(48TPI)	5.25-inch(96TPI)		3.5-inch	
		JA-56x/JU-465	JA-58x/59x/JU-475		
Exerciser	FDD-EXT-5	※ ←	※ ←	※ ←	1
Alignment diskette	817-128	817-560	817-581	JU-01AA (DAD only)	1~2
Work diskette	2D	2DD	2HD	2DD	1~2
CMOS/TTL adaptor				YTFDD-CN35	1
Limmiter Adfust Tool (5.25-inch)					1
Oscilloscope (50 MHz)					1
Probe (10:1)					3
Frequency counter					1

Note: ※ ←: Stand for the same as left.

: DAD (Dynamic Alignment Diskette)

4. OUTLINE OF MAINTENANCE

- The following tools are required for maintenance of a Floppy Disk Drive. (FDD)

4.1 Alignment Diskette

Alignment diskette is used for head actuator alignment and index sensor adjustment.

- **Adjustments** (Refer to table 8.1)

- (1) Specify an applicable model from Tabel 8.1, and make a read/write head radial adjustment at a specified track. (Sides 0,1)
- (2) Make an index timing adjustment at a specified track. (Sides 0, 1)
- (3) Make an azimuth measurement at a specified track. (Sides 0, 1)

CAUTION

Do not write when using alignment diskette. Check that write protect sensor is properly operating.

4.2 Exerciser

The exerciser enables you to make all adjustments and inspections necessary for an FDD. Its functions include the following:

- (1) Seek increment or alternate tracks
- (2) Read (but no data compare)
- (3) Write 1F or 2F (All 0's or 1's)
- (4) Head load (5.25-inch FDD with optional head loader)
- (5) Recalibration to track 00

The exerciser has switches and indicators to execute a specified function.

5. DIAGNOSTIC PROCEDURES

5.1 Error Symptom Recognition

Errors that occur because of the wrong operating procedure, wrong programming, or use of a defective diskette, or soft errors due to external causes, such as contaminated air and random electrical noise, are often attributed to a drive failure or maladjustment.

Unless a visual inspection of the drive reveals an evident assembly fault or a defect, always confirm errors with another good diskette, and another known good drive.

5.2 Soft Error Detection and Correction

Soft errors are normally caused by the following:

- (1) Contamination between read / write heads and diskette. This kind of contamination can be easily eliminated by the liner in the diskette.
- (2) Random electrical noise, normally a few microseconds or less.
- (3) Small defects in written data and / or track not detected during write operation may cause soft errors during read.
- (4) Faulty grounding of the drive or host system can also cause a soft error.
- (5) Wrong motor speed is another cause of soft errors.

Take the following steps on the controller side to recover from the soft errors mentioned above.

- (1) Read the track again ten times or until the data is recovered.
- (2) If Step (1) above fails to recover the data, access the adjacent. Then return the head to the original track.
- (3) Repeat Step (1).
- (4) Any error that cannot be corrected by the above procedure is irrecoverable.

5.3 Write Error

If an error occurs during write operation, it is usually detected during the next revolution by performing a read operation called write check. To correct an error, write again and repeat a write check operation. If the result is unsatisfactory after ten or more write operations, perform a read operation on another track to determine whether it is the diskette or the drive that is wrong. If an error persists, replace the diskette and repeat the above procedure.

If the error still persists, consider the drive defective. If the error is corrected, dispose of the diskette as defective.

5.4 Read Error

Most read errors are soft errors. Data can be recovered by following the recovery procedure mentioned in 5.2.

5.5 Seek Error

(1) Stepper motor or stepper motor drive circuit is faulty.

(2) **Faulty carriage**

There are two ways of seek error recovery. One is to recalibrate to track 00, and seek back to the original track.

The other is to read the ID field, check the track number on which the head is located, and move the head away from it. And read it again.

5.6 Compatibility Error

The data which is written by one drive may not be read by another. This error is called a compatibility error, which can be caused mostly by the following. The check points are also mentioned below:

(1) Head misalignment: Refer to (Adjustments and Confirmation Item 9.5)

(2) Head output too low: Refer to (Adjustments and Confirmation Item 9.3)

(3) Motor speed difference: Refer to (Adjustments and Confirmation Item 9.1)

6. TROUBLE ANALYSIS

To determine the cause of trouble whether it lies in the FDD, diskette, or controller, replace the disk and FDD with good ones. If the FDD is assumed faulty as a result, follow the procedure below.

6.1 Trouble Analysis Procedure

FDD trouble may occur in any of the following ten forms.

- (1) Index detection failure
- (2) Not ready
- (3) Track 0 undetectable
- (4) No seek
- (5) No write
- (6) No read
- (7) Read error
- (8) IN USE LED won't light.
- (9) Write protect undetectable
- (10) No head load (5.25 -inch FDD with optional head loader)

Check with the troubleshooting flowchart in 6.2.

CAUTION:

Be sure to switch power off before removing an FDD or PCB from the operating system.

6.2 Trouble Shooting Flow Chart

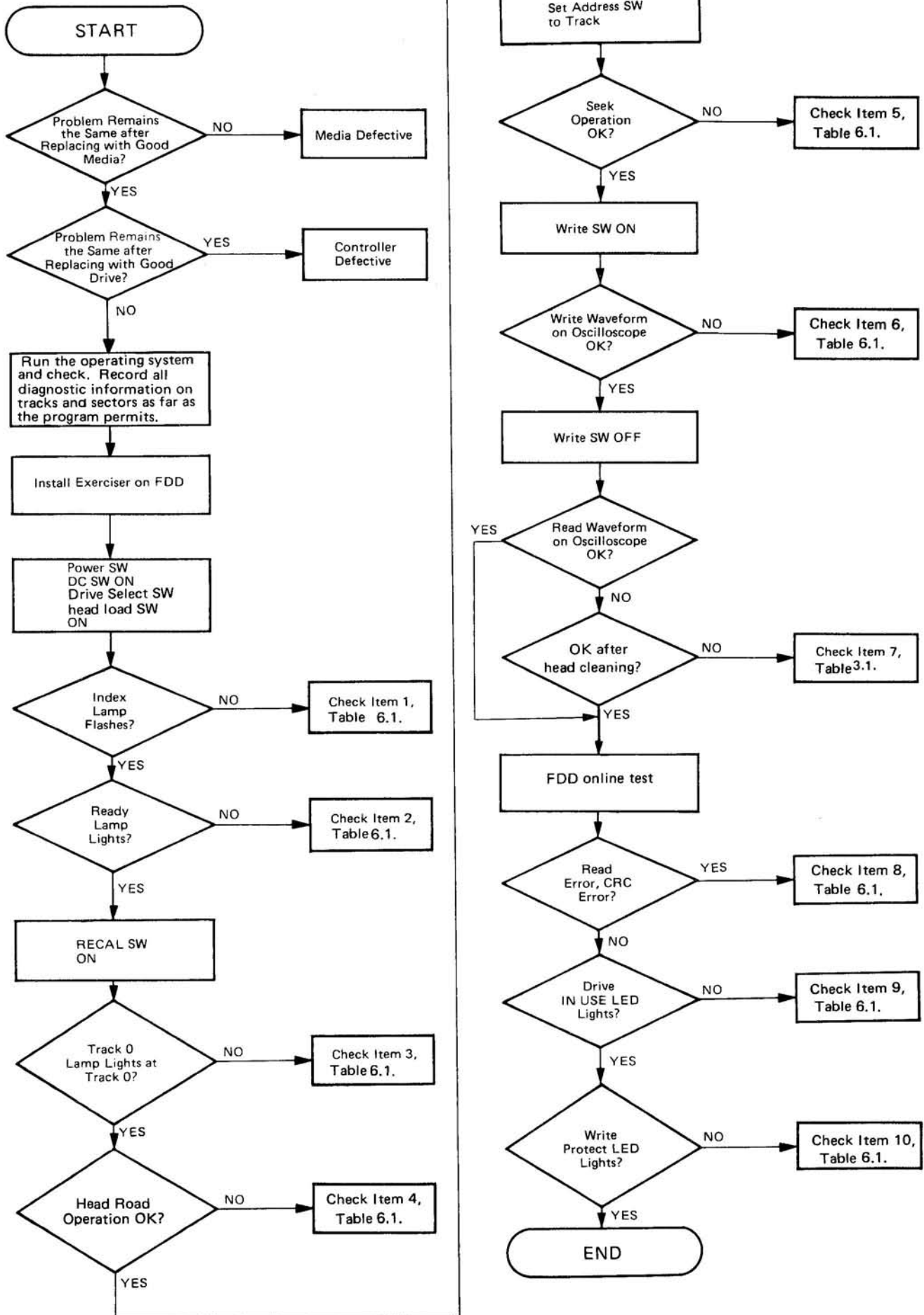

6.3 Trouble Analysis Table

Table 6.1

Item	Trouble	No.	Cause	5.25-inch	JU-3x3, 3x4	JU-3x2
1	Index detection failure	1	Collet part faulty	Replace		
		2	DD motor control PCB	Replace	Replace DD motor, Base assembly	Replace DD motor assembly
		3	DD motor faulty	Replace		
		4	Index LED faulty	Replace	Replace DD motor, Base assembly	Replace
		5	Index detector faulty	Replace		
		6	Index LED/index detector installation faulty	Adj.		
		7	PCB motor ON circuit	Repair	※ ←	※ ←
		8	PCB index detection circuit	Repair	※ ←	※ ←
2	Not ready	1	See Item 1.			
		2	PCB ready circuit	Repair	※ ←	※ ←
3	Track 0 detection failure	1	Track 00 assembly	Replace	※ ←	※ ←
		2	PCB track 0 detection failure	Repair	※ ←	※ ←
4	No head loading	1	See Item 1.			
		2	See Item 2.			
		3	HDL solenoid	Replace		
		4	PCB HDL circuit	Repair	※ ←	※ ←
5	No seek	1	Stepper motor	Replace	※ ←	※ ←
		2	Guide shaft contamination or damaged	Replace	※ ←	※ ←
		3	PCB stepper driver circuit	Repair	※ ←	※ ←
6	No WRITE	1	See Item 1.			
		2	See Item 4.			
		3	Head disconnected	Replace	※ ←	※ ←
		4	Head shorted	Replace	※ ←	※ ←
		5	HDL bail height wrong	Adj.		
		6	PCB write circuit	Repair	※ ←	※ ←
7	No READ	1	See Item 1.			
		2	See Item 4.			
		3	See Item 6.			
		4	PCB read circuit	Repair	※ ←	※ ←
8	READ ERROR	1	See Item 1.			
		2	See Item 4.			
		3	See Item 7.			
		4	Alignment	Adj.	※ ←	※ ←
		5	Azimuth	Unadjustable	※ ←	※ ←
		6	Burst	Adj.	Unadjustable	Unadjustable
		7	Asymmetry	Adj.	Adj.	
		8	Limiters	Unadjustable	Adj.	Adj.
		9	Flag 0	Adj.	※ ←	※ ←
		10	HDL time	Adj.		
		11	Index period	Adj.	Replace DD motor, Base assembly	Replace
		12	PCB read circuit	Repair	※ ←	※ ←
9	IN USE LED won't light.	1	LED part	Replace	※ ←	※ ←
		2	PCB IN USE circuit	Repair	※ ←	
10	Write protect failure	1	Write protect part	Replace	Replace DD motor, Base assembly	Replace
		2	Write protect circuit		※ ←	※ ←

Note: ※ ←: Stand for the same as left.

7. PREVENTIVE MAINTENANCE

No preventive maintenance is necessary for any type of FDDs under normal conditions of use.

8. MEASUREMENT ITEMS FOR EACH MODEL

Table 8.1

Item	Parameter	JU-312, 313, 314		JU-32X, 36X		JU-581, 585	
		TRK	Value	TRK	Value	TRK	Value
1	Index period	20	200 ± 3ms	40	200 ± 3ms	32	166.7 ± 0.2 ms
2	Output level	39	160 mV or more	79	180 mV or more	76	120 mV or more
3	Radial Alignment	20	75%	40	50%	32	70%
4	AZIMUTH	20	± 18'	40	± 18'	68	± 18'
5	Index burst	20	3 ± 1.5ms	40	3 ± 1.5ms	68	200 ± 200 μs
6	FLAG 0	From track 1 to track 2 and back	1:1	From track 1 to track 2 and back	1:1	From track 2 to track 3 and back	1:1
7	Limiter	- 1	Recalibrate and return to 0	- 1	Recalibrate and return to 0	- 1	Recalibrate and return to 0
8	Asymmetry	39	<600ns	79	<600ns	76	<350 ns
9	Head load time						<50 ms

Item	Parameter	JU-591, 595, 475		JU-455/465		JU-455-5	
		TRK	VALUE	TRK	Value	TRK	Value
1	Index period	32	166.7 ± 0.2 ms (High) 200 ± 0.2 ms (Low)	16/32	200 ± 0.2 ms	16	200 ± 0.2 ms
2	Output level	76	120 mV or more	39/79	140/120 mV or more	39	140/mV or more
3	Radial Alignment	32	70%	16/32	70%	16	70%
4	AZIMUTH	68	± 18'	34/68	± 18'	34	± 18'
5	Index burst	68	200 ± 200 μs	34/68	200 ± 200 μs	34	200 ± 200 μs
6	FLAG 0	From track 2 to track 3 and back	1:1	From track 1 to track 2/track 2 to track 3 and back	1:1	From track 2 to track 3 and back	1:1
7	Limiter	- 1	Recalibrate and return to 0	- 1	Recalibrate and return to 0	- 1	Recalibrate and return to 0
8	Asymmetry	76	<350 ns	39/79	<600 ns	39	<600 ns
9	Head load time		<50 ms		<50 ms		

9. ADJUSTMENTS AND VERIFICATIONS

9.1 Motor Speed Adjustment and Confirmation (Index Period)

- (1) Insert a diskette, run the motor, and clamp. Refer to the index period column of Table 8.1 for the applicable model.
- (2) Step to the specified track.
- (3) Connect a frequency counter to the INDEX signal.
 - 5.25-inch: TP7
 - 3.5-inch: IX
- (4) Check that the frequency counter readings meet the specifications in the table.
- (5) **Adjustment**
 - 5.25-inch: Turn the speed control potentiometer on the motor control circuit board until the specifications are satisfied.
 - 3.5-inch: No adjustment

9.2 Write Protect Verification

- (1) Check that the exerciser's write protect lamp goes on and off as a media is inserted and removed as specified in the table below.

	Media with write protect hole open	Media with write protect hole closed
5.25-inch	OFF	ON
3.5-inch	ON	OFF

9.3 Head Output Verification

Use a new diskette if possible to identify head failure for this check.

- (1) Insert a good diskette.
- (2) Run the motor.
- (3) Step to the track specified in the output level column of **Table 8.1**.
- (4) Connect the oscilloscope probe as specified below.

	CH1	CH2	EXT
5.25-inch	TP1	TP2	TP7
3.5-inch	T1	T2	IX (INDEX)

Invert channel 2 and select the Add mode.

Set vertical deflection to 10 mV/division and horizontal deflection to 20 ms/division.

- (5) Write 2F (all ones) on the entire circumference.
(In case of a double-sided FDD, repeat it on sides 0 and 1 using SIDE SELECT.)
- (6) Check that the average output level meets the specifications of **Table 8.1**. If it does not meet the specifications, refer to Item 7 of the Trouble Analysis Table.

9.4 Output Modulation Verification

Modulation: M is calculated by the following formula.

$$M(\%) = \frac{V_{\max} - V_{\min}}{V_{\max} + V_{\min}} \times 100$$

calculated value is 20% or less.

using the value obtained in 9.3, and check that the

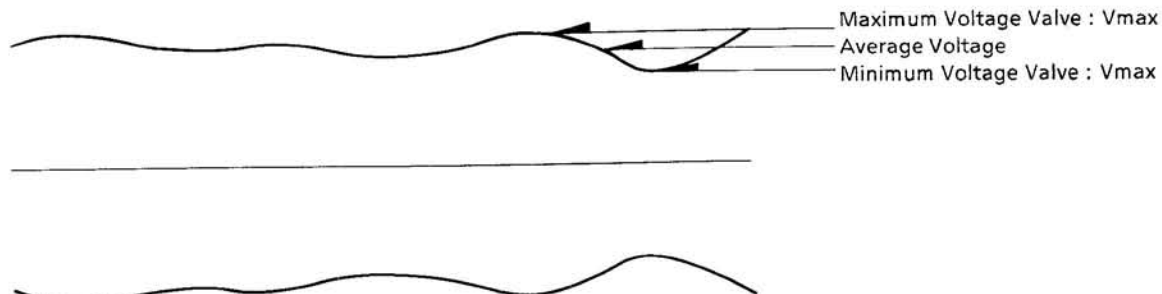

Fig. 9.1 Modulation

9.5 Radial Alignment Adjustment

Introduction

This adjustment is normally not necessary.

If the mounting screws for the stepper motor loosen, or if parts become defective, or if a compatibility error occurs, check and readjust according to the following procedure.

Steps (4) to (9) should be performed regardless of the type, CE or DAD alignment diskette used. Use an alignment diskette suitable to the type of FDD to be adjusted according to table 3.1.

- (1) Insert an alignment diskette.

CAUTION:

Be sure to leave the alignment diskette under room conditions for 20 minutes before adjustment.

- (2) Step to the track specified in the Radial alignment column of Table 8.1.
- (3) Leave the oscilloscope in the same condition as mentioned in section 9.3.

• Cats Eye System 5.25-inch

- (4) Check the output waveforms for sides 0 and 1. They should appear as in Fig. 9.2.
- (5) The two waveforms should appear in the amplitude ratio in the R/A column of Table 8.1 or better.
- (6) If the specified ratio is not satisfied, loosen the two mounting screws for the stepper motor.
- (7) Move the stepper motor along the base by hand until the two waveforms assume approximately the same amplitude, and retighten the mounting screws. (See Fig. 9.2.)
- (8) Step the head outward (track 0) and inward (track 40 or 79), and confirm that the adjustment has been completed.
- (9) After the radial adjustment, be sure to confirm track 00 sensor adjustment 9.8 and carriage limiter 9.9.

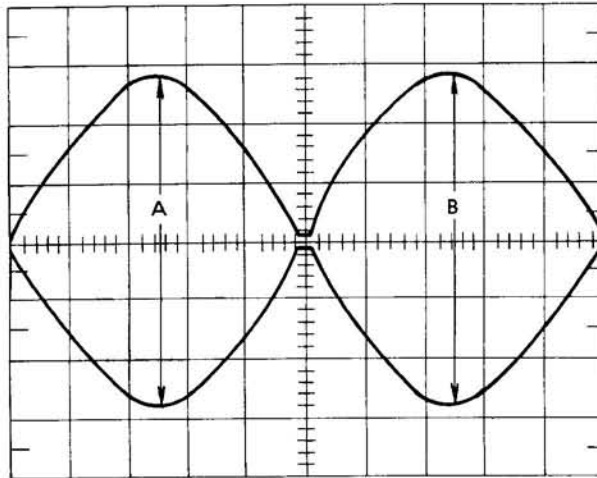

$$A > B : \frac{B}{A} \times 100$$

$$B > A : \frac{A}{B} \times 100$$

Fig. 9.2 Radial Alignment Waveforms (CATS EYE)

Note: Sides 0 and 1 are adjusted to agree at the factory . If they disagree, adjust them to meet the specifications of Table 8.1

• DAD (Dynamic Alignment Diskette) 3.5-inch

(4) Watch the output waveforms for sides 0 and 1. They should appear as shown in Fig. 9.3.

(5) Measure the timing levels A1 to A4 and B1 to B4 in Fig. 9.3, and calculate the lobe ratio from the following formulas.

$$\Sigma A > \Sigma B : \frac{\Sigma B}{\Sigma A} \times 100\% \quad \Sigma A < \Sigma B : \frac{\Sigma A}{\Sigma B} \times 100\%$$

(6) The lobe ratio calculated by the above formulas should meet the specifications on item 3 of Table 8.1.

(7) If the above requirement is not met, loosen the two mounting screws for the stepper motor, adjust.

(8) Seek from track 0 to track 40 and from track 79 to track 40, and confirm that the adjustment has been completed.

(9) After the radial adjustment, be sure to confirm track 00 sensor adjustment 9.8 and head carriage limiter 9.9.

Note: An alignment instrument for 3.5-inch FDDs permits accurate and easy adjustment because the lobe ratio is displayed on the instrument.

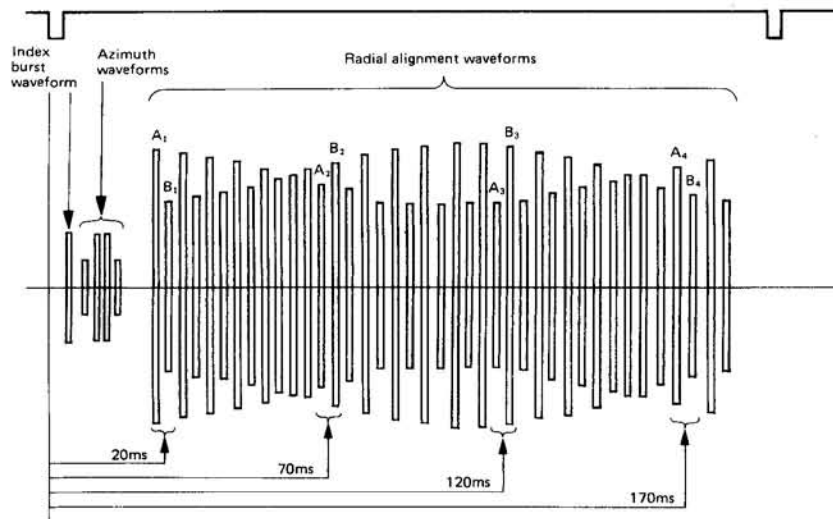

Fig. 9.3 Alignment Waveform (DAD)

9.6 Azimuth Verification

- (1) Insert an alignment diskette. Seek to the track specified in the azimuth column of **Table 8.1**.
- (2) Set the oscilloscope in the same conditions as in **8.3**, and set horizontal deflection to 0.5 ms/division.
- (3) Measure as shown below.
- (4) Confirm that the measured value meets the specifications in the azimuth column of **Table 8.1**.

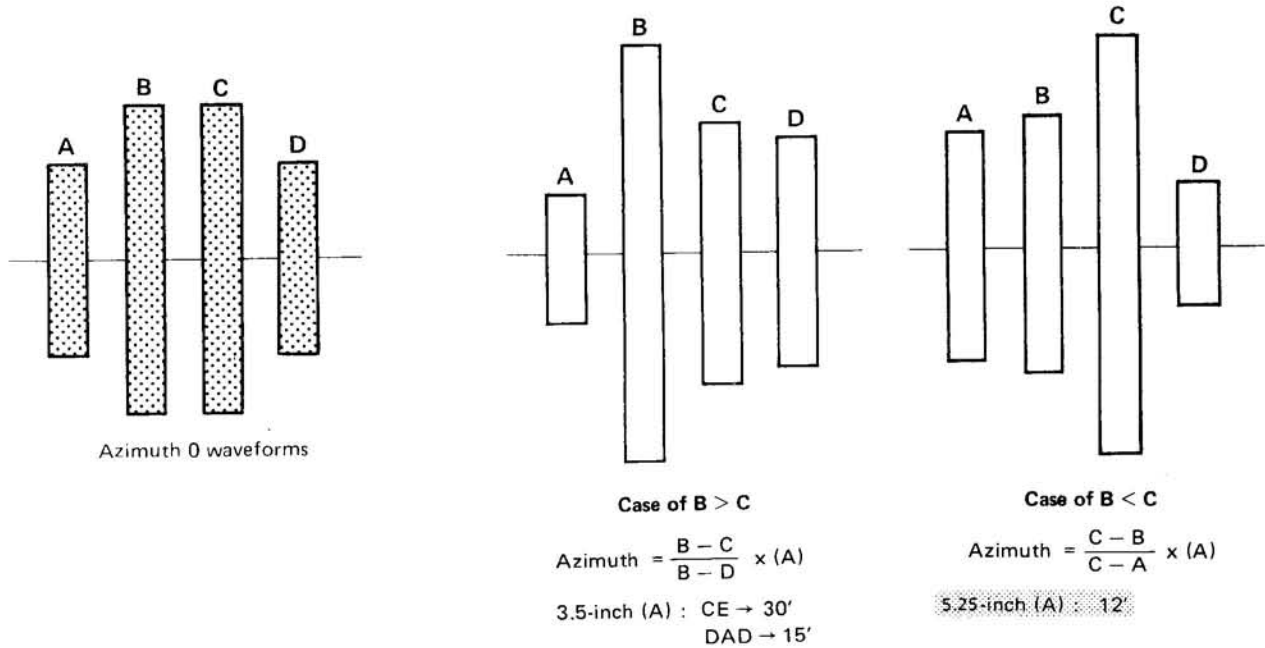

Fig. 9.4 Azimuth Waveforms

9.7 Index Burst Verification

- (1) Insert an alignment diskette. Seek to the track specified in the I/B column of **Table 8.1**.
- (2) Set the oscilloscope time base as follows:
 - 5.25-inch: 50 μ s/division
 - 3.5-inch: 1 ms/division
- (3) Check that the time from oscilloscope start to the first data pulse meets the I/B specifications of **Table 8.1**. (DAD system)
- (4) If the specifications are not met, adjust as follows. (No adjustment necessary for 3.5-inch models)
 - Loosen the index detector mounting screws enough to free the assembly.
 - Adjust the timing to $200 \pm 200 \mu$ sec.
 - Retighten the screw.
 - Check the timing again.

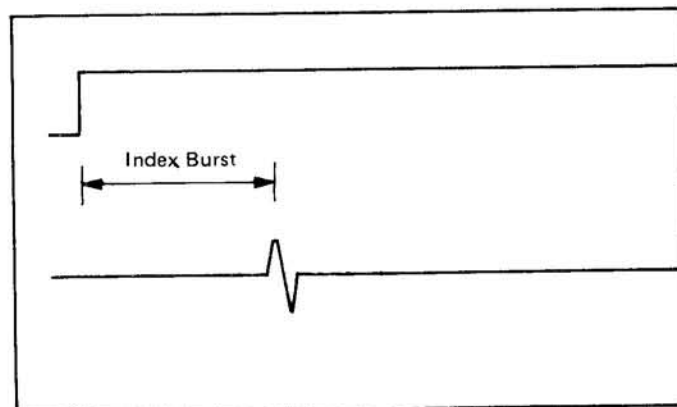

Fig. 9.5 Index Timing

9.8 Track 00 Sensor Adjustment

- (1) Set the oscilloscope as follows.
Set horizontal deflection to 1 ms/division.

	CH1	EXT
5.25-inch	TP-8	TP-12
3.5-inch	ZP	SP

- (2) Step between specified tracks at in the FLAG 0 item of Table 8.1 (Turn the seek delay switch on the exerciser to adjust 12 ms seek.)
- (3) Loosen the track 0 sensor screw and adjust until the waveform on the oscilloscope appears as shown in Fig. 9.6.

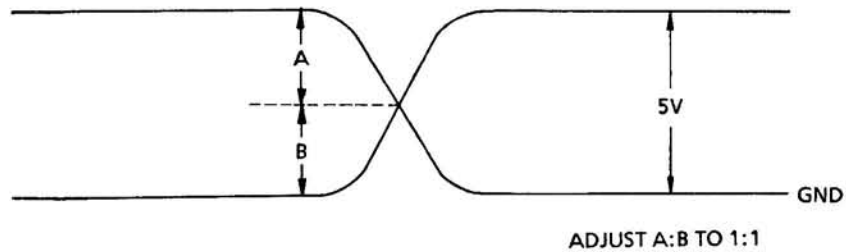

Fig. 9.6 Track 0 Waveform

9.9 Limiter Verification (5.25-inch)

- (a.) Seek to track 00.
- (b.) Push the carriage outward until it contacts the limiter, and recalibrate.
Make sure that the carriage moves inward and returns to track 00.
- (c.) If the carriage does not return to track 00 in Step (b), or if it contacts the limiter of the stepper motor, the stepper motor assembly must be replaced because adjustment is useless.

9.10 Limiter Adjustment (3.5-inch)

- (1) Seek to track 0.
- (2) Write 2F data on track 0, and measure read level.
- (3) Loosen the limiter mounting screw to free the limiter.
- (4) Move the limiter until it just touches the head carriage on -1 track, and retighten the limiter mounting screw securely.
- (5) Check that, when the RECAL switch on the exerciser is pushed ON, the head returns to track 0 and that the 2F output level is the same as that measured in Step (2).

9.11 Asymmetry Verification

- (1) Insert a work diskette.
- (2) Step to the track specified in the symmetry item of Table 8.1.
- (3) Set the oscilloscope as follows:

	CH1	CH2
5.25-inch	TP-6	TP1
3.5-inch	RD	T1

- (4) Write 1F.
- (5) A read wave form is displayed on the oscilloscope as shown in Fig. 9.7.
- (6) Confirm if it satisfies the value as shown in Fig. 8.1.

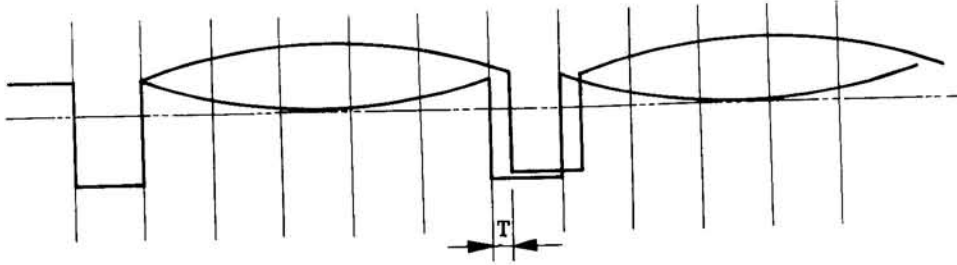

Fig. 9.7 Asymmetry Waveform

10. PANASONIC ALIGNMENT DISKETTE

5.25 inch Alignment Diskette

Table 10.1.

TPI	P/N		Index Burst	Azimuth	Radial	MODEL
48	817-128		34TRK	34TRK	16TRK	JA-55X JU-455
96	817-560		68TRK	68TRK	32TRK	JA-56X JU-465
96	817-581		68TRK	68RTRK	32TRK	JU-475 JU-58X JU-59X
100	817-570		61TRK	61TRK	36TRK	JU-570

3.5 inch Alignment Diskette

Table 10.2.

TPI	P/N		Index Burst	Azimuth	Radial	MODEL
67.5	JU-01AA		20	20	20	JU-31X
135	JU-01AA		40	40	40	JU-32X JU-36X

PART II

11. REMOVALS AND INSTALLATIONS

11.1 PCB Removal and Installation (See Fig. 11.1)

- (1) Remove the two printed circuit board mounting screws.
- (2) Disconnect the connectors (J3 CON, J4 CON, J6 CON, J5 CON, J8CON) from the printed circuit board.
- (3) Remove the printed circuit board by sliding it aslant.
- (4) To reinstall, reverse the above procedure.
- (5) Readjustment is not necessary after printed circuit board replacement.

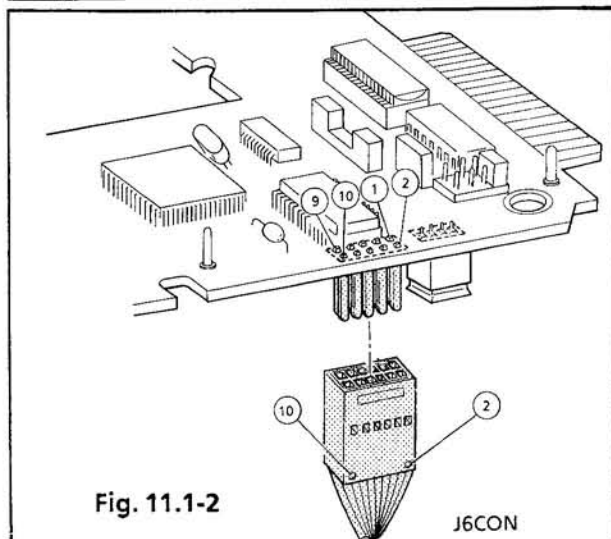
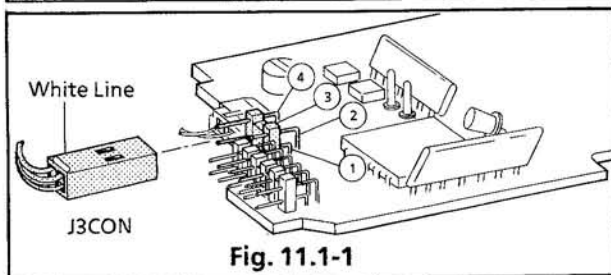
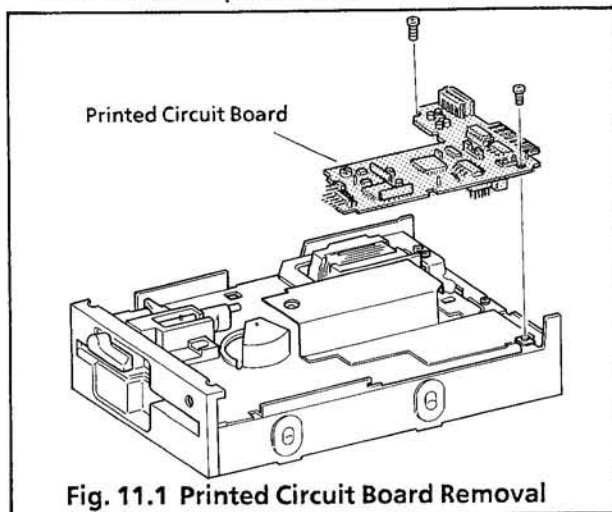

Note:

Reverse connection prevention pin is not provided in J3 and J6. When installing the P.C.B. board, connect them so that the white line on the J3 connector is facing upwards and J6 connector pin No. matches the P.C.B. side pin No.

11.2 Front Plate Removal and Installation (See Fig.11.2)

- (1) Operate the lock cam of the clamp assembly, and turn the clamp handle in the direction of clamping.
- (2) Remove the clamp handle.
- (3) Remove the two front plate mounting screws, and take off the front plate.
- (4) Reverse the above procedure to reinstall.

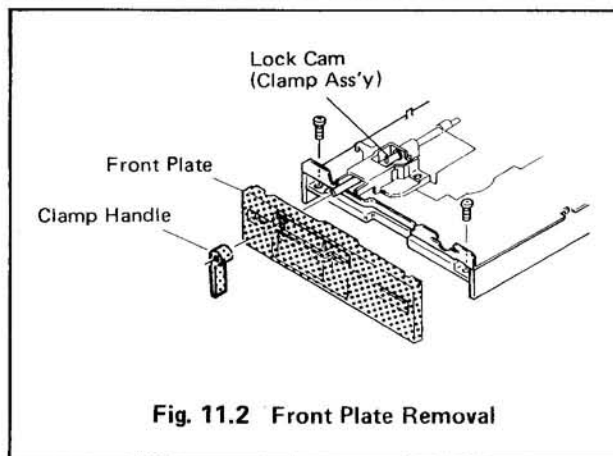

11.3 Track 00 Assembly Removal and Installation (See Fig. 11.3)

- (1) Remove the track 00 assembly mounting screw and take out the track 00 assembly.
- (2) Pull out the white, yellow, and green wires from J6 CON (10P).
- (3) Reverse the above procedure to reinstall.
- (4) After reinstallation, adjust the track 00 sensor as described in 9.8.

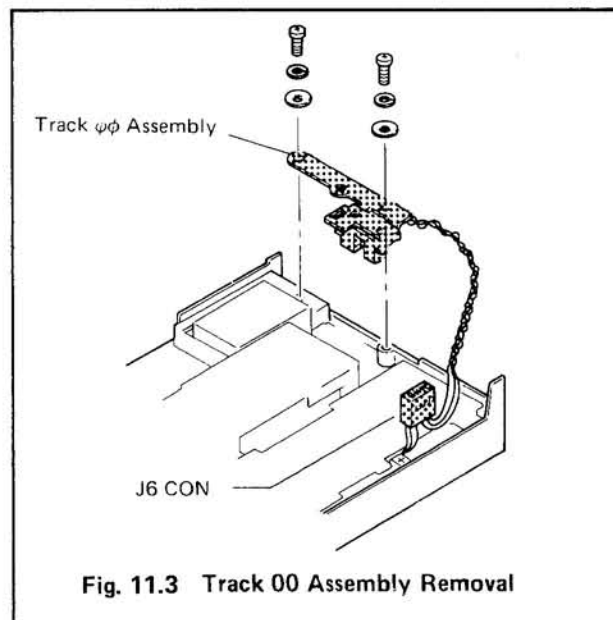

11.4 Collet Assembly Removal, Installation, and Adjustment (See Fig.11.4)

- (1) Remove the Cartridge Guide Assembly as described in 11.7
- (2) Remove the lifter spring from the lifter.
- (3) Remove the E-ring from the lifter shaft.
- (4) Remove the lifter from the Cartridge Guide.
- (5) Remove the Collet Assembly from the Guide shaft.
- (6) Reverse the above procedure to reinstall.
- (7) After reinstallation, perform collet assembly center adjustment.
- (8) Collet assembly center adjustment.
 - a) Temporarily fasten the Cartridge Guide Assembly.
 - b) Insert a diskette or dummy diskette and clamp it.
 - c) Clamp repeatedly a few times to find a good fit between the collet and the inside diameter of the DD motor.
 - d) Bind the screw of the Cartridge Guide.
 - e) Check step c) again, if not good repeat steps a) through d) until the correct center adjustment is achieved.

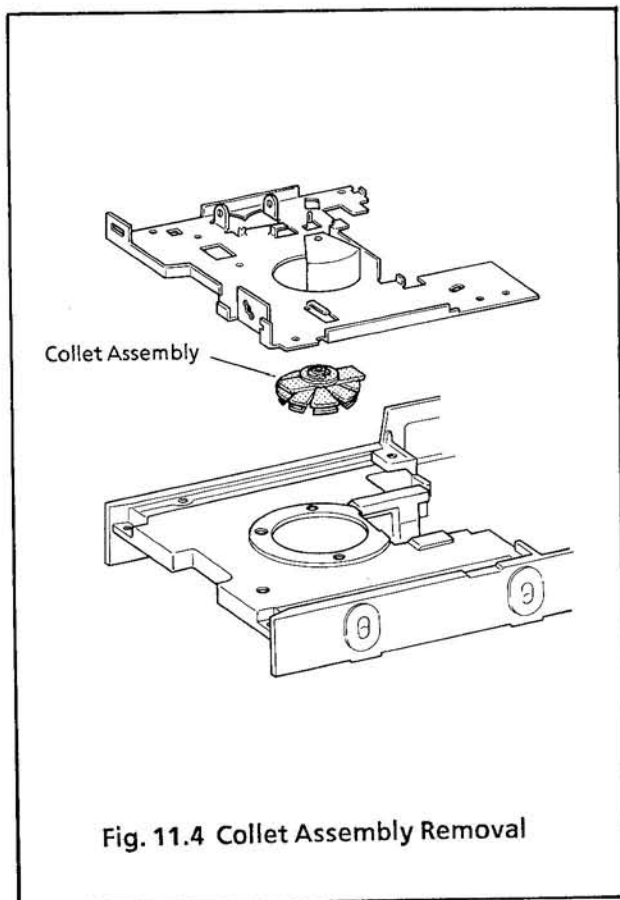

11.5 Clamp Assembly Removal and Installation

- (1) Remove the front plate as described in 11.2.
- (2) Remove the two clamp assembly mounting screws.
- (3) Remove the clamp assembly.
- (4) Reverse the above procedure to reinstall.

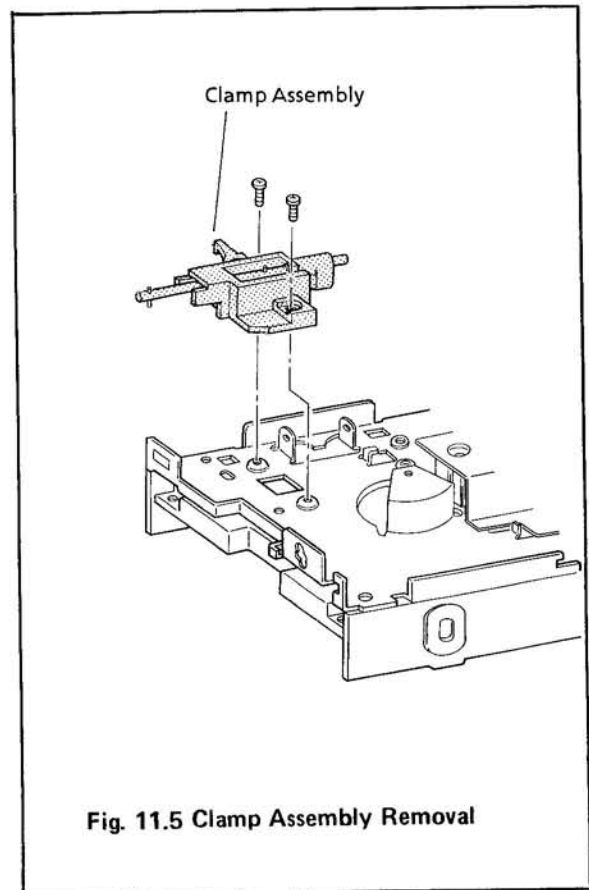

11.6 Write Protect Sensor/Index Detector Assembly Removal and Installation (See Fig. 11.6)

- (1) Remove the front plate as described in 11.2.
- (2) Remove the write protect sensor mounting screw and index detector mounting screw respectively.
- (3) Remove the write protect sensor/index detector assembly.
- (4) Reverse the above procedure to reinstall.
- (5) When reinstalling the write protect sensor, exercise care so that the leads and write protect sensor will not project from the bottom and side of the base.
- (6) After index detector installation, adjust the index timing as described in 9.7.

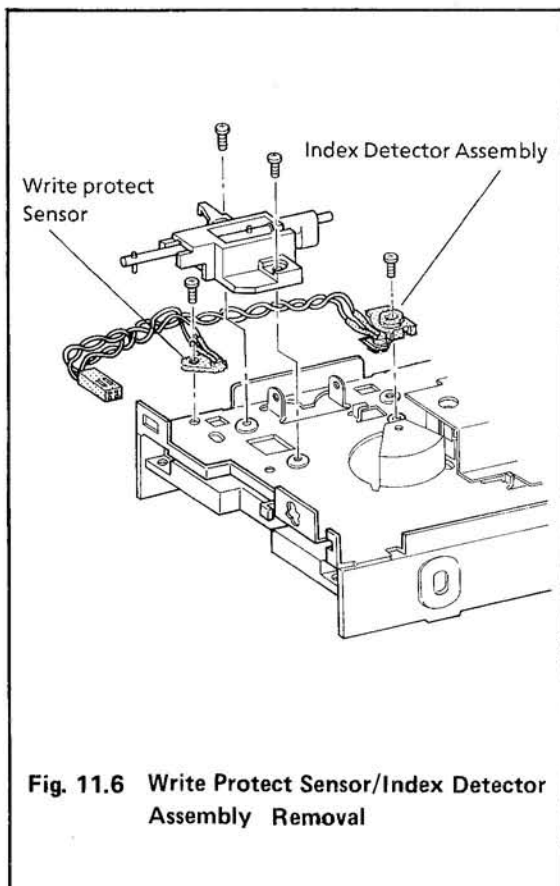

11.7 Cartridge Guide Assembly Removal and Installation (See Fig. 11.7)

- (1) Remove the printed circuit board as described in 11.1.
- (2) Remove the front plate as described in 11.2.
- (3) Remove the shield plate mounting screw and take the shield plate off.
- (4) Remove the write protect sensor as described in 11.6. It is not necessary to remove the index detector.
- (5) Remove the four cartridge guide mounting screws and take out the cartridge guide assembly.
- (6) After reinstallation, adjust the collet assembly as in 11.4 step (6) and adjust the index timing as in 9.7.
- (7) When removing or reinstalling, be careful not to damage the carriage arm with the lifter.

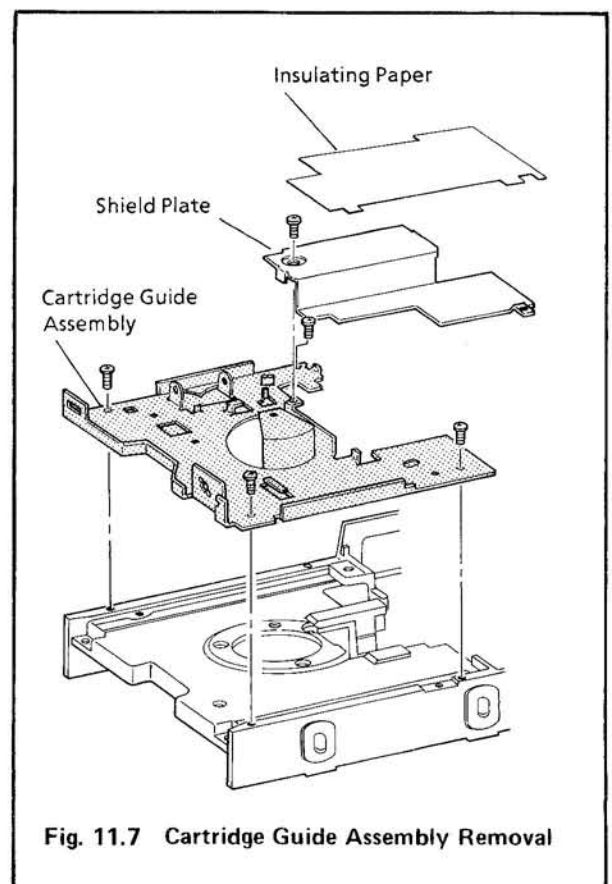

11.8 Stepper Motor Assembly Removal and Installation (See Fig. 11.8)

- (1) Remove the insulating paper and shield plate.
- (2) Remove the track 00 sensor as described in 11.3.
- (3) Remove the two (M2 x 4) actuator screws that fasten the actuator to the carriage arm assembly.
- (4) Remove the two (M3 x 6) stepper motor assembly mounting screws and then the stepper motor.
- (5) Reverse the above procedure to reinstall.
- (6) After reinstallation, perform limiter check as in 9.10 and radial alignment adjustment as in 9.5.
- (7) Adjust the track 00 sensor according to the instruction in 9.8.

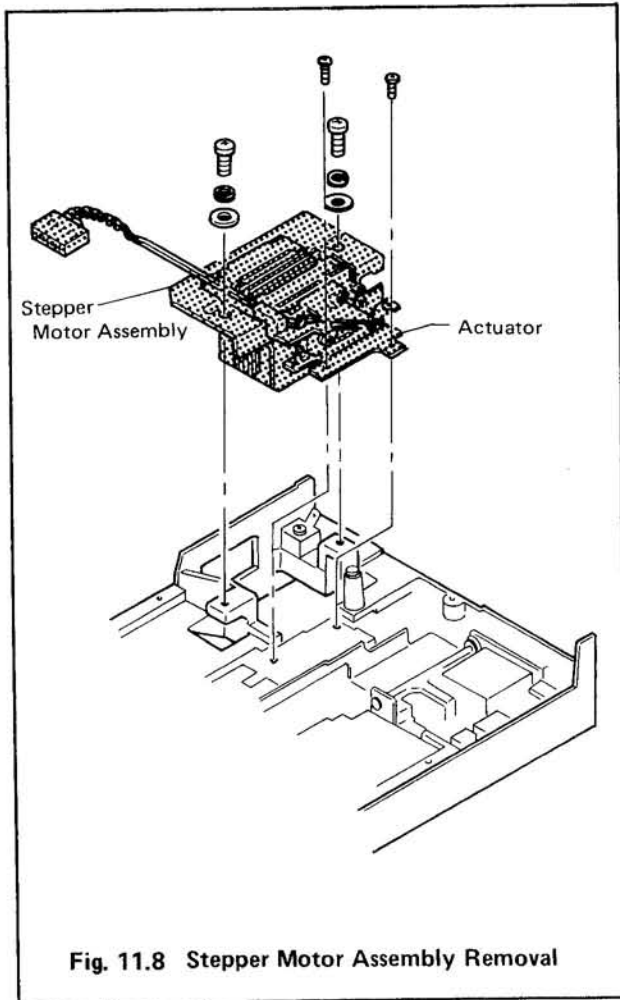

11.9 Carriage Arm Assembly Removal and Installation (See Fig. 11.9)

- (1) Remove the printed circuit board as described in 11.1.
- (2) Remove the insulating paper and shield plate.
- (3) Remove the track 00 assembly as described in 11.3.
- (4) Remove the stepper motor assembly as described in 11.8.
- (5) Remove the two guide rod clamp mounting screws.
- (6) Remove the carriage arm assembly, guide rod clamp, and guide rod.
- (7) Pull out the guide rod from the carriage arm assembly.
- (8) Reverse the above procedure to reinstall.
- (9) After replacement, perform limiter adjustment as described in 9.10, track 00 sensor adjustment as described in 9.8, and radial alignment adjustment as described in 9.5.

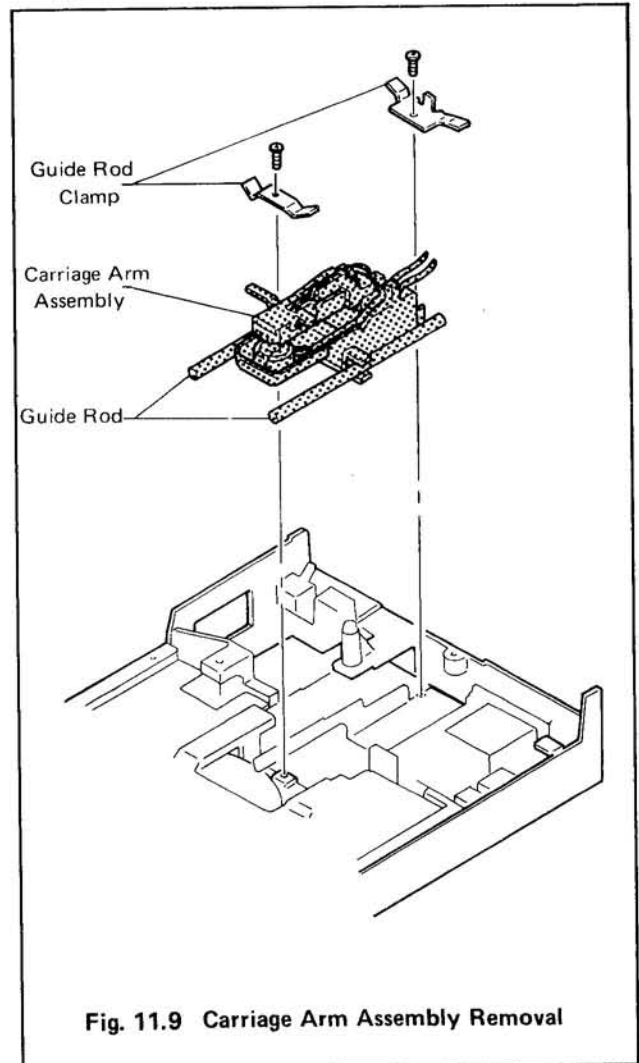

11.10 Drive Motor Removal and Installation (See Fig. 11.10)

- (1) Remove the printed circuit board as described in 11.1.
- (2) Remove the insulating paper and shield plate.
- (3) Remove the front plate as described in 11.2.
- (4) Remove the write protect sensor as described in 11.6.
- (5) Remove the cartridge guide assembly as described in 11.7.
- (6) Remove the three drive motor mounting screws and take off the drive motor from the base.
- (7) Disconnect the drive motor connector pins from the connector.
- (8) Reverse the above procedure to reinstall.
- (9) When reinstalling, make sure that the drive motor connector is connected in the correct direction.
- (10) After reinstalling, perform motor speed adjustment as described in 9.1 and also the adjustments necessary upon reinstallation of the cartridge guide as described in 11.7.

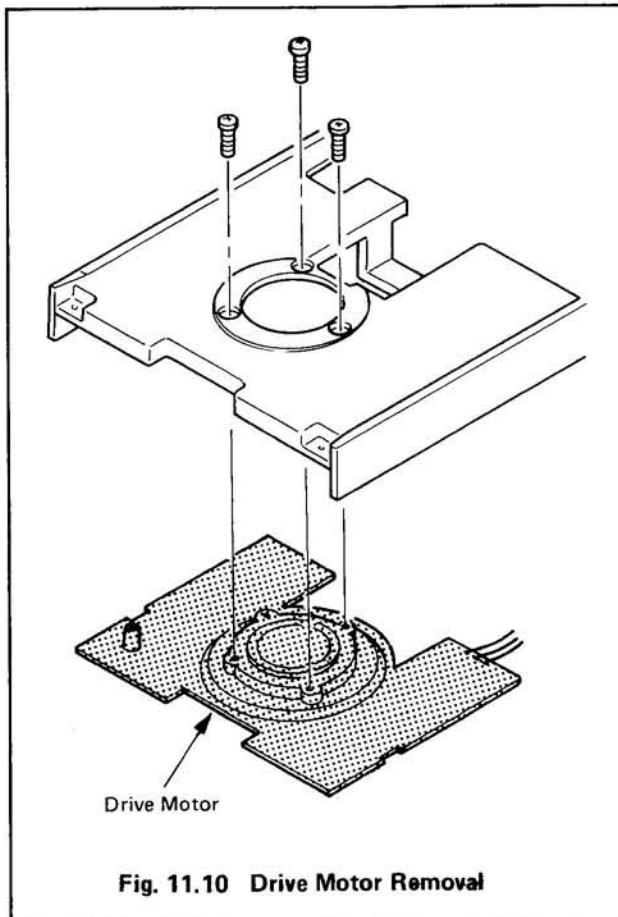

11.11 LED Assembly Removal and Installation

- (1) Remove the clamp handle and front plate.
- (2) Disconnect the connectors J8 CON from the printed circuit board.
- (3) Remove the LED Assembly by sliding it aslant from the Cartridge Guide Assembly.
- (4) Reverse the above procedure to reinstall.

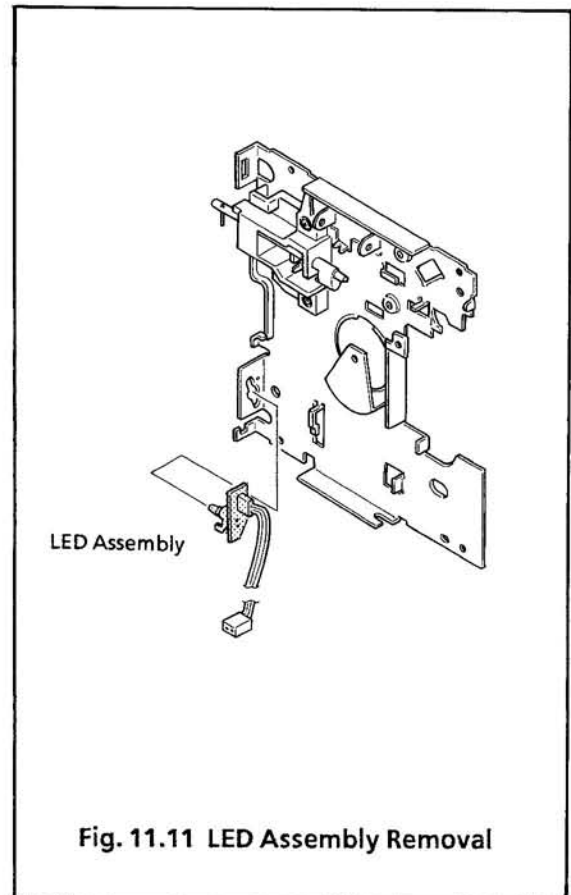

12. TEST POINTS

Printed Circuit Board
(Top view)

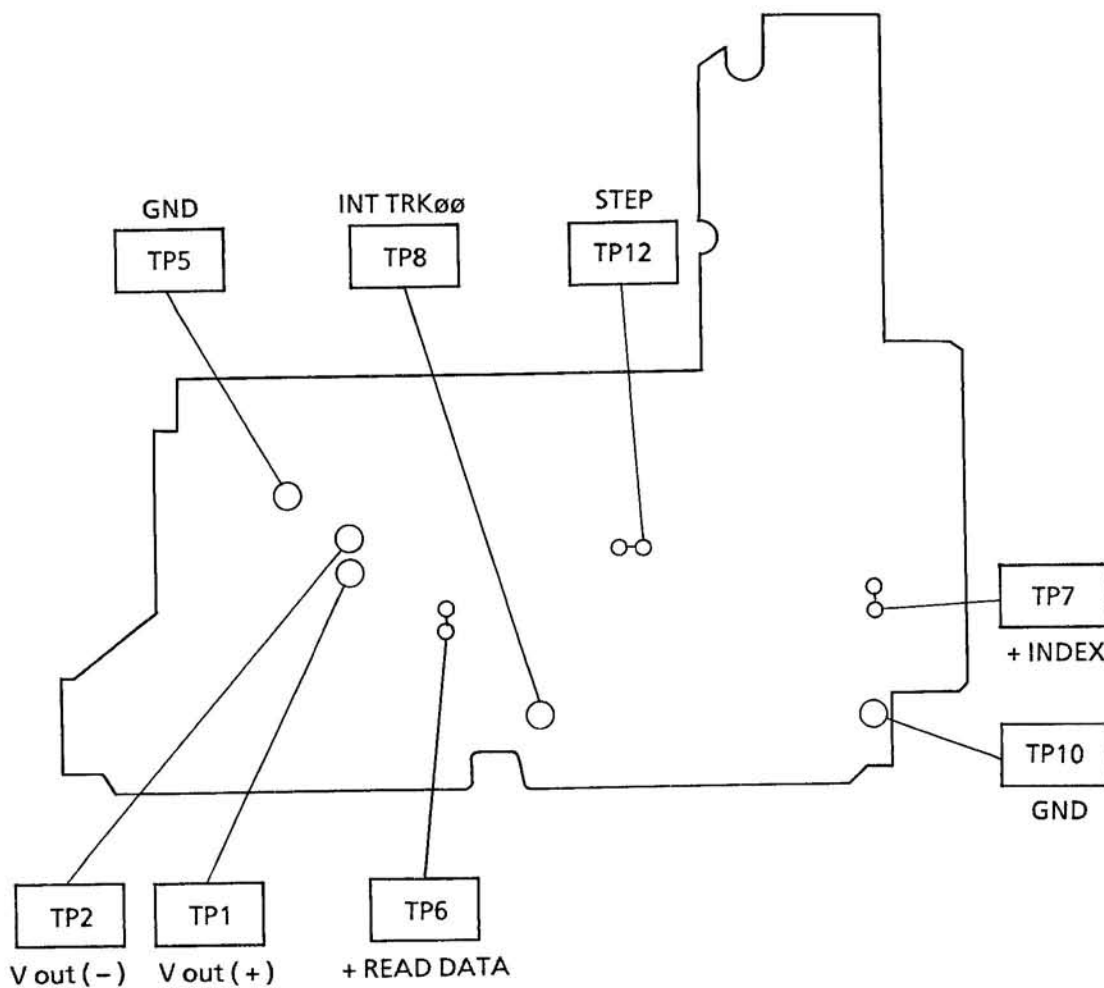

13. EXPLODED VIEW

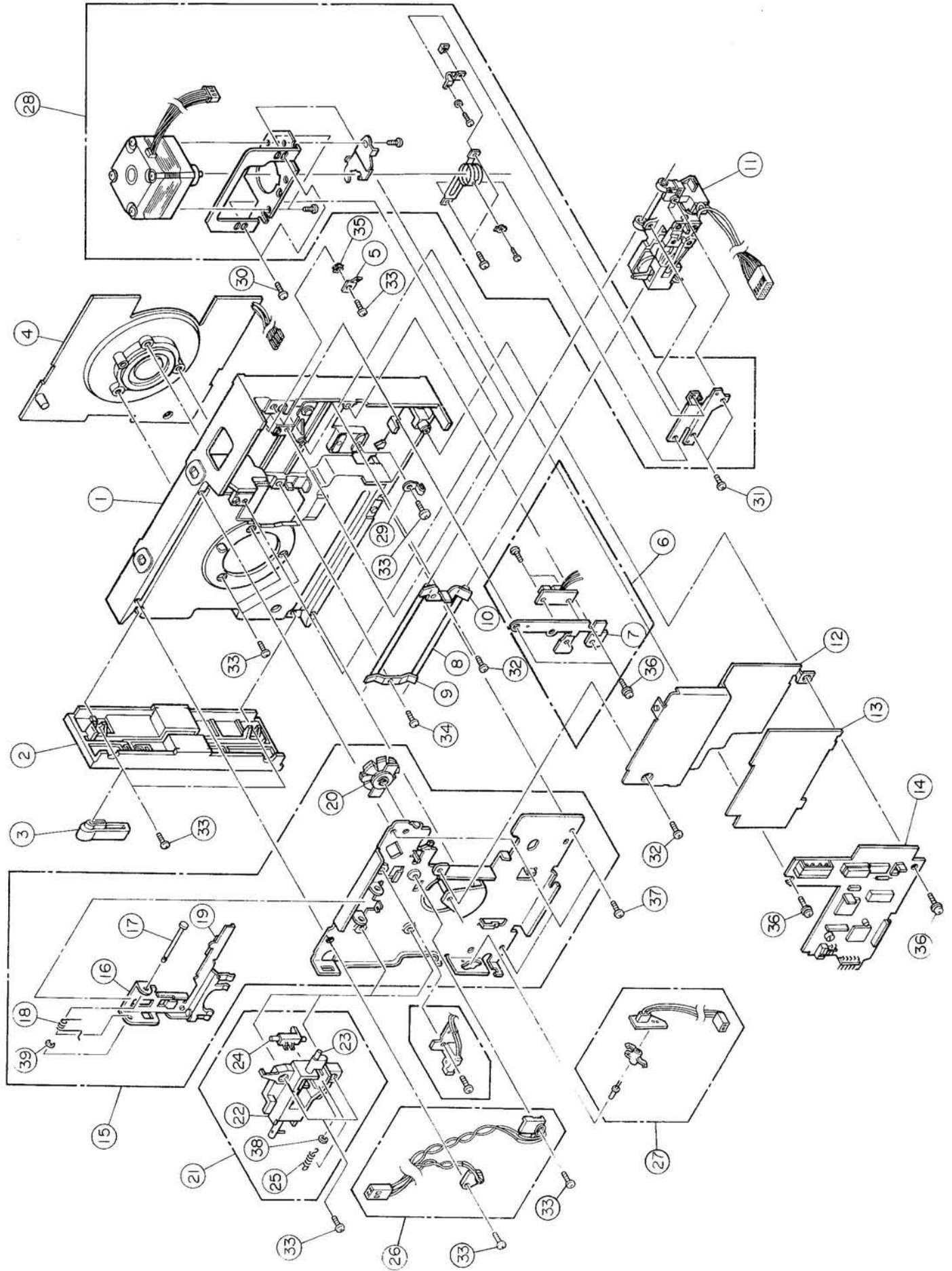

14. REPLACEMENT PARTS LIST

MODEL: JU-455-5

Ref. No.	Part No.	Description	Per Set (pcs.)
1	YTF3L01901B1	Base	1
2	YTF5W00152B2	Front Panel	1
3	YTF6A01090B3	Clamp Handle	1
4	YTFMD00790B4	Drive Motor	1
5	YJ617612	Faston	1
6	YTUF56TRK-2T	Sensor Assembly (For TRK \emptyset)	1
7	YTF2T01560B4	Bracket (For TRK \emptyset)	1
8	YTF2E02561B4	Guide Rod	2
9	333D46331360	Clamp (For Guide Rod Head)	1
10	YJF2E00580B4	Clamp (For Guide Rod End)	1
11	YTUF55HD	Head Carriage Assembly	1
12	YTF2H03582B3	Shield Plate	1
13	YTF2P03591B4	Insulating Paper	1
14	YTUF55PK-5	PCB Assembly	1
15	YTUF55CG	Cartridge Guide Assembly	1
16	YTF3C02732B3	Lifter	1
17	YTF4H01360B4	Lift Shaft	1
18	YTF4J01901B4	Lift Spring	1
19	333D46817500	Pat	1
20	YTUF56CLT2AN	Collet Assembly	1
21	UF45CP3CAE1	Clamp Assembly	1
22	YJF4F00341B2	Clamp Bearing	1
23	YTF4H01720B3	Clamp Cam Assembly	1
24	333D36817692	Lock Cam	1
25	333D46624770	Lock Spring	1
26	YTUF45WP4AAA	Write Protect Assembly	1
27	YTUF45LED	LED Assembly	1
28	YTUF55SM	Stepper Motor Assembly	1
29	YTF1G00500B4	Cord Clamp	1
30	YTF1E00300B4	Washer Head Screw	2
31	XSB2 + 4V	Screw (M2x4 Bind)	2
32	XSB3 + 4V	Screw (M3x4 Bind)	2
33	XSB3 + 6FX	Screw (M3x6 Bind)	11
34	XSB3 + 6V	Screw (M3x6 Bind)	1
35	XWC3B	Toothed Lock Washer	1
36	XYN3 + F6	Screw (M3x6 Sems)	4
37	Y-1283	Screw (M3x6 Bind)	3
38	XUC3	Retaining Ring	1
39	XUC2	Retaining Ring	1

- Caution:
1. PCB Assembly is produced to order during the production period only.
 2. When you order the aforementioned parts, be sure to specify "Part No." of the parts ordered.

15. REPLACEMENT PARTS LIST OF PCB

MODEL: JU-455-5
Component Side (Top)

Ref. No.	Part No.	Description	Per Set (pcs.)
R6	ERDS1TJ681	Carbon Resistor	1
C1	ECEA1HKS100E	Electrolyte Capacitor	1
C2,3,5	FCJ00080B400	Ceramic Capacitor	3
C4	ECEA1HKS010E	Electrolyte Capacitor	1
CN	FJC00080B400	Connector	1
CN	FJC00080B401	Connector	2
CN	FJC00090B402	Connector	2
CN2	YJ172294-1	Connector	1
CN2	YJ172296-1	Clamp	1
CN3	YTFFC4TLBW1B	Connector	1
CN4	YJFJC00230B4	Connector	1
CN7	YTFFC2LBW1B	Connector	1
CN8	FJC00180B400	Connector	1
IR1	EXBRB7151JW	Block Resistor	1
IR2	EXBP84472J	Block Resistor	1
IR4	EXBL85368J	Block Resistor	1
IR6	EXBG88359S	Block Resistor	1
L	FNC00030B426	Low-Frequency Coil	2
L	YJBL02RN2R62	Choke Coil	2
L5	FNC00030B418	Low-Frequency Coil	1
L6	ELEPG330KA	Choke Coil	1
L9	LAL03KH101K	Choke Coil	1
VR	EVMQ0G01KB24	Variable Resistor	1
X	YJCSA4.00MG	Resonator	1
16	DN74LS16-1S	IC	1
38	DN74LS38-1	IC	1
P	FJP00110B400	Plug	7
XV	YJDILB14P8JC	IC Socket	1
HA1342 1	HA13421	LSI	1
HA1664 2	HA16642MP	IC	1
FQL000 8	FQL00081B4	LSI	1

Solder Side (Bottom)

Ref. No.	Part No.	Description	Per Set (pcs.)
R1,2,3	FRA00010B428	Chip Resistor	3
R7	FRA00040B432	Chip Resistor	1
R8	FRA00040B496	Chip Resistor	1
R9	FRA00050B420	Chip Resistor	1
R10,11	FRA00040B477	Chip Resistor	2
R12	FRA00040B486	Chip Resistor	1
R13	FRA00040B464	Chip Resistor	1
R20	FRA00040B472	Chip Resistor	1
R21	FRA00040B442	Chip Resistor	1
R22,23, 24,25, 27	FRA00040B470	Chip Resistor	5
R28	FRA00040B478	Chip Resistor	1
R29	FRA00040B468	Chip Resistor	1
C6,7,24	FCC00060B408	Chip Capacitor	3
C8,9	FCC00040B420	Chip Capacitor	2
C10,11, 15,16, 26	FCC00020B401	Chip Capacitor	5
C18	FCC00070B409	Chip Capacitor	1
C19,23	FCC00010B440	Chip Capacitor	2
C20	FCC00010B456	Chip Capacitor	1
C25	FCC00010B444	Chip Capacitor	1
CN5	YTB4B-PH	Connector	1
CN6	FJC00220B403	Connector	1
D	MA151WK-TW	Diode	5
D	MA151WK-TX	Diode	5
D	MA159-TW	Chip Diode	1
D	MA159-TX	Chip Diode	1

16. SCHEMATIC DIAGRAM (JU-455-5)

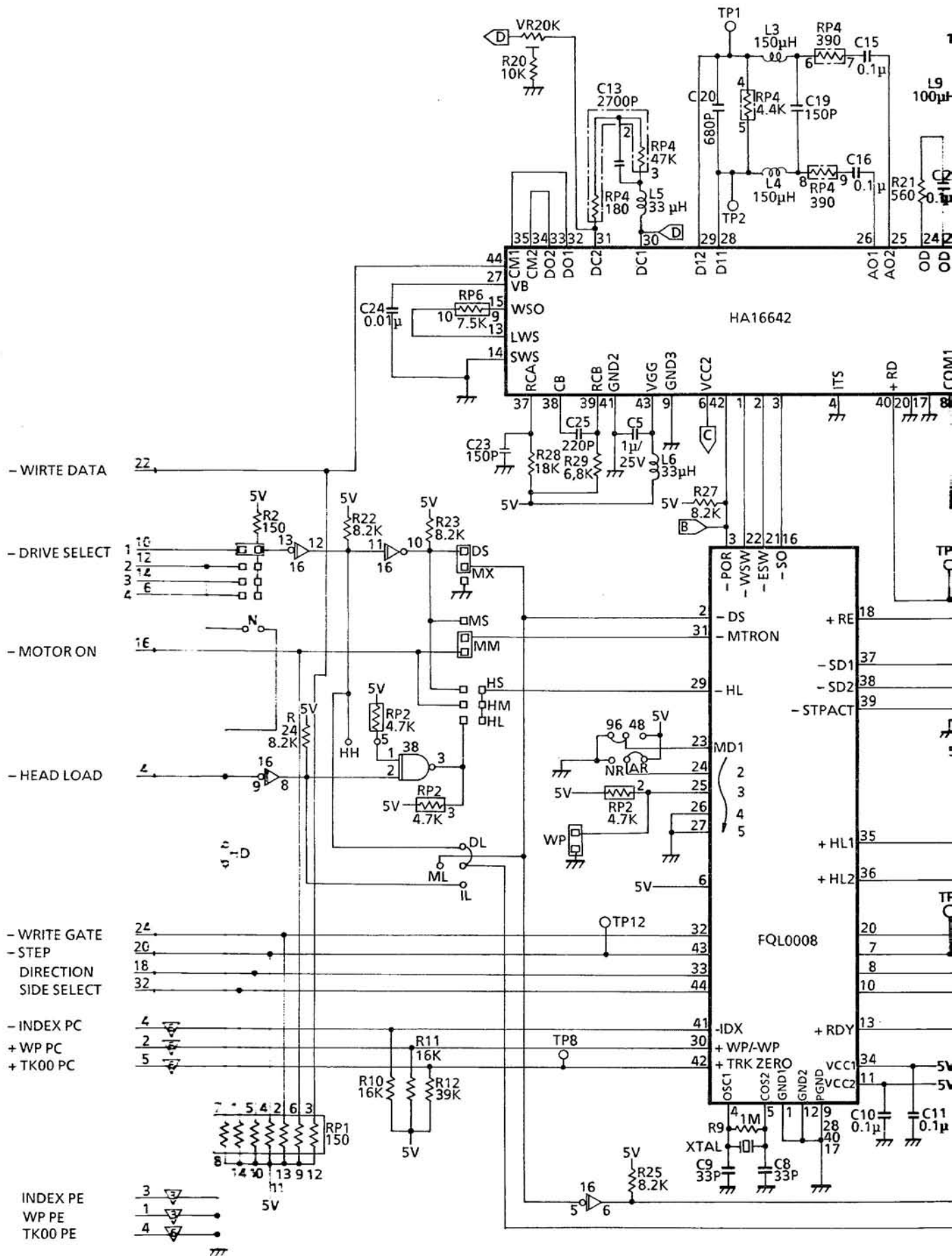

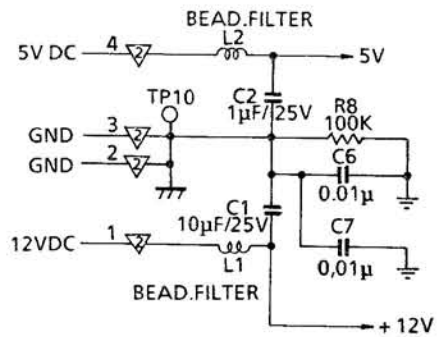
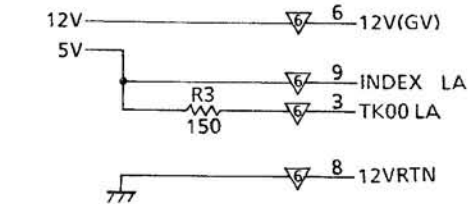
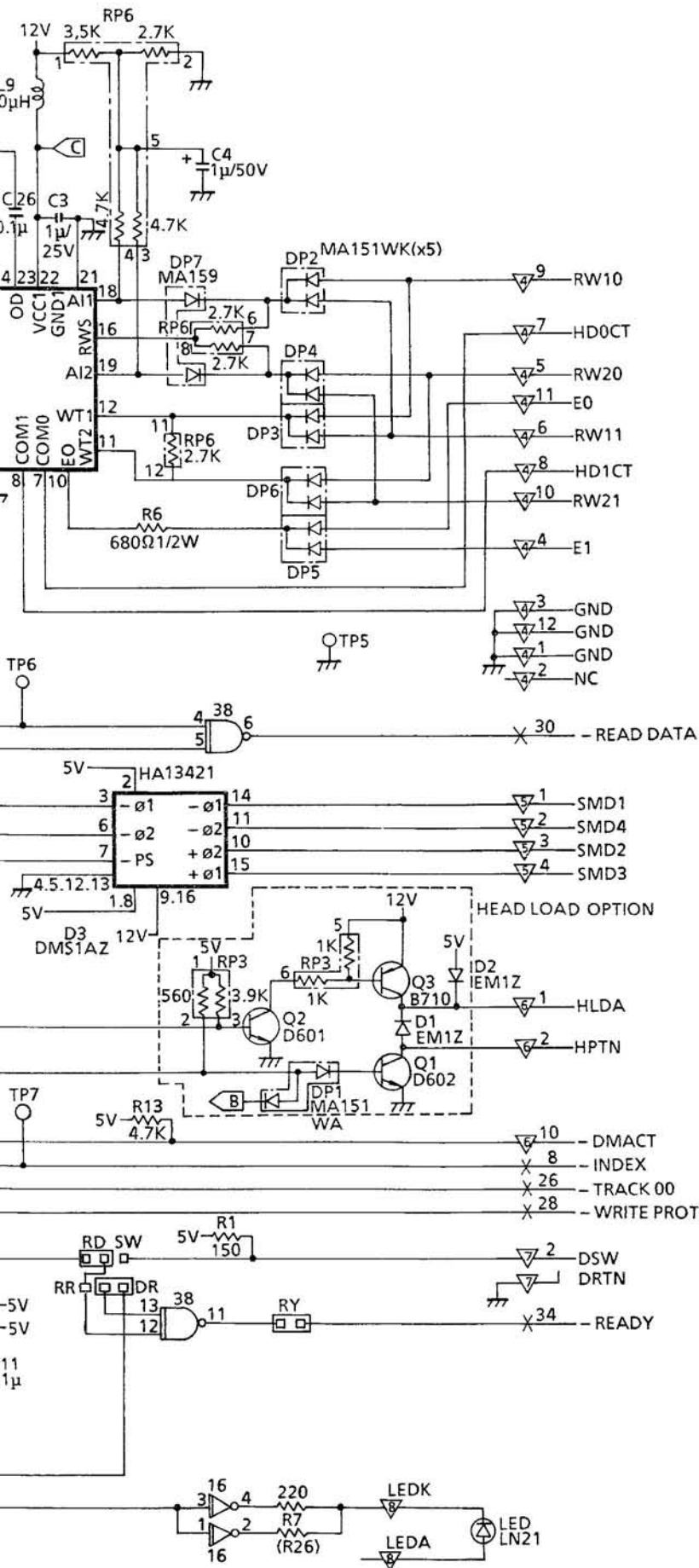

17. CIRCUIT BOARD

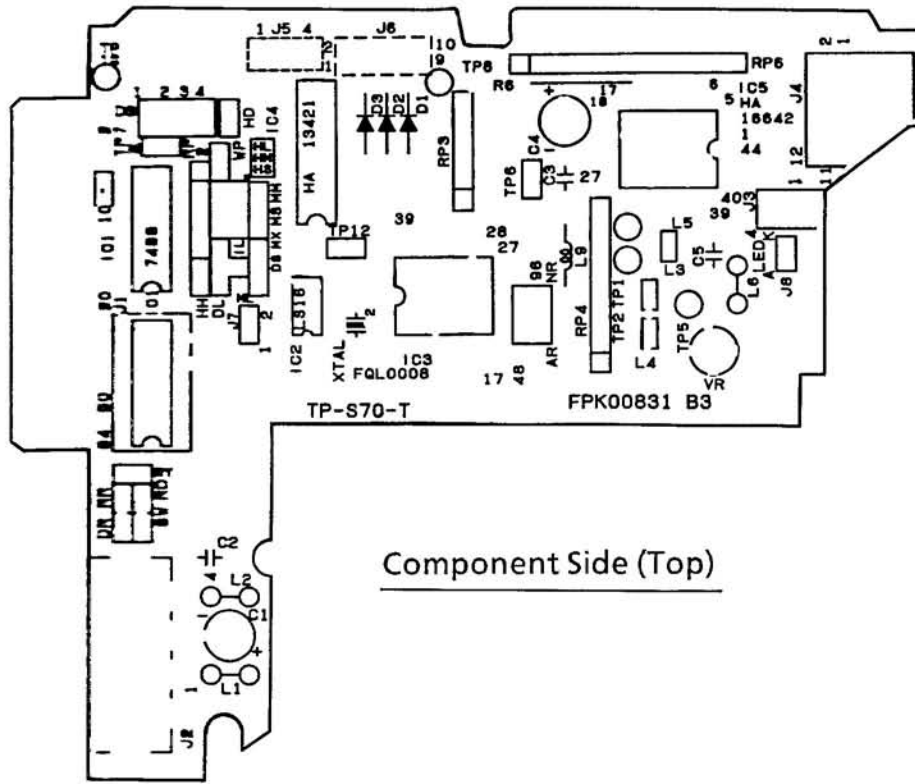

Component Side (Top)

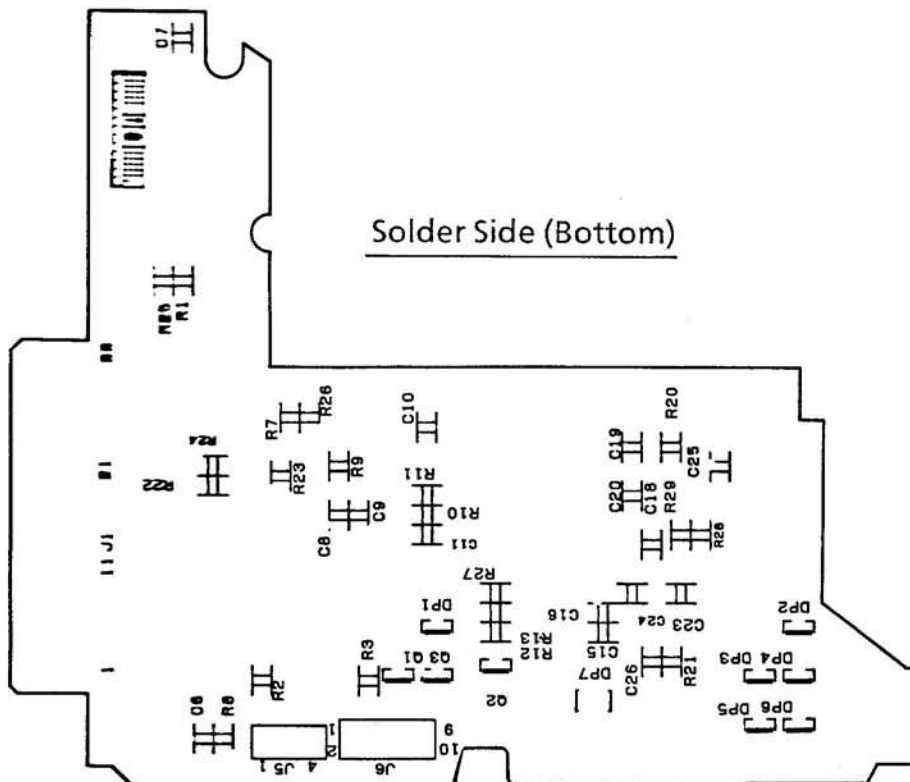

Solder Side (Bottom)

18. BLOCK DIAGRAM

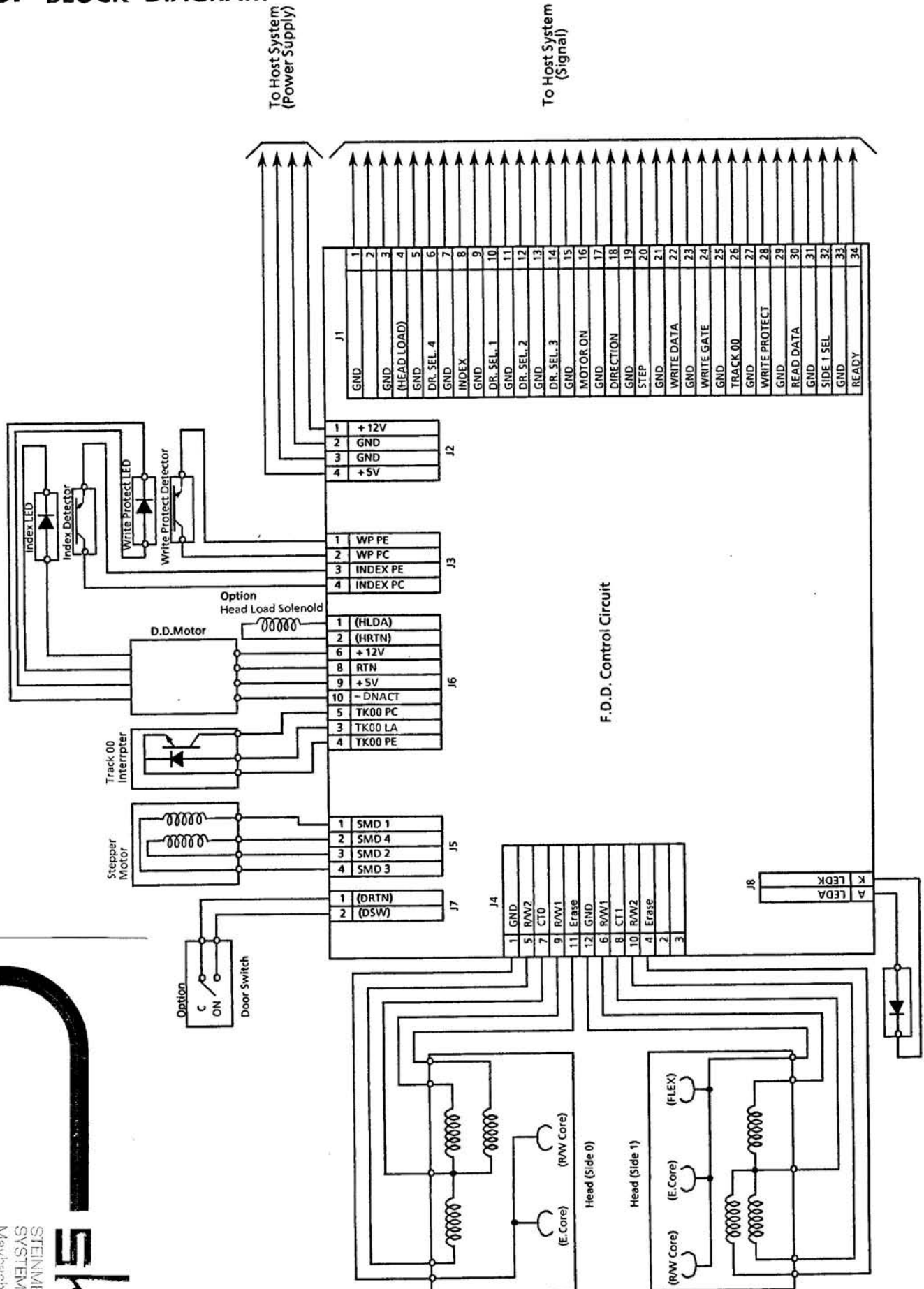

SKS
 STEINMETZ, KRISCH
 SYSTEMTECHNIK
 Maybachstraße 10
 7500 Karlsruhe 41
 Telefon 07 21 / 40 36
 Telex 17 826 934 ssk

Helmut Wiertalla
 Abteilungsleiter Software