

# SOLID STATE DATA DISPLAY OWNER'S MANUAL

## SPECIFICATIONS

Input Signals	Composite Video Signal, Negative SYNC. 1.0 ± 0.2 V <sub>p-p</sub> , 75Ω
CRT Size	31 cm diag. (12 inch diag.)
Phosphor	P31 (GREEN)
Semiconductors	IC 1 Transistors 14 Diodes 16
Video Amp Bandwidth	18 MHz
Display Format	1920 Characters max. (80 char. x 24 lines)
Power Input	AC 220 V, 50 Hz
Power Consumption	26 W
Dimensions	32 (W) x 28.4 (H) x 20.8 (D) cm
Weight	7.3 kg.

\*Specifications are subject to change without notice.

# Introduction

Your new solid state data display is a precision engineered product designed for use with the computer system which outputs a composite video signal.

This picture tube employs an implosion proof, green phosphor. This data display is equipped with DC restoration (In the absence of a data signal, the data display screen will be fully black: no raster).

Solid state electronics used in this data display provides improved reliability and superior performance even in continuous duty applications.

# Controls

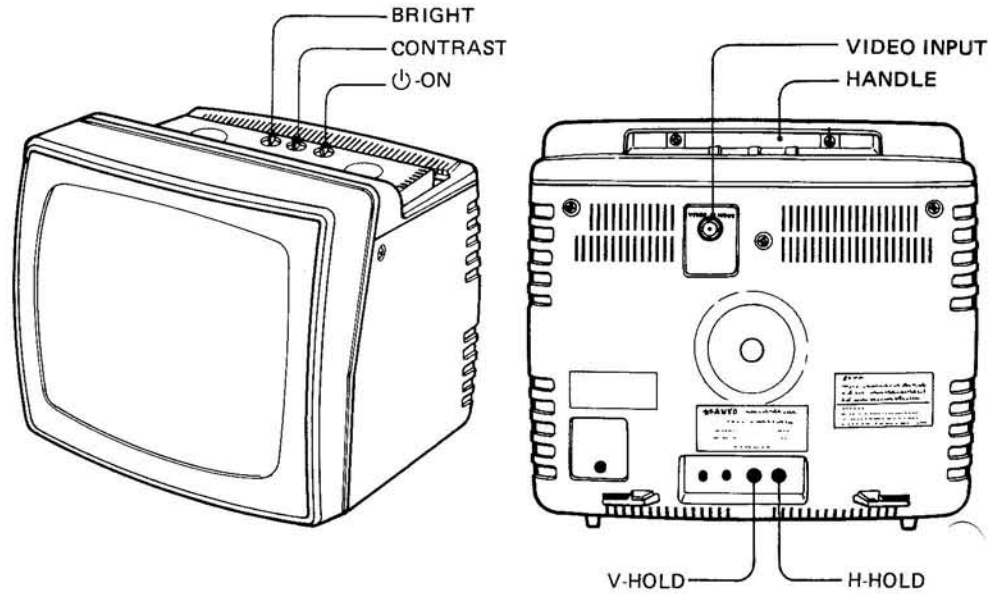

# Installation

**CONNECT.....**Data Display to an outlet supplying 220 volts, 50 Hertz, alternating current(AC) only.

**FOLLOW.....**Instructions on all tags and labels before attempting to operate your display.

## ACHTUNG

Die in diesem Gerät entstehende Röntgenstrahlung ist ausreichend abgeschirmt.

Beschleunigungsspannung:

Maximal 17 kV.

## CAUTION

- For installation, avoid excessively hot or humid places as well as dusty locations. Damage to the cabinet or electronic parts failures may result.
- Avoid any small object or water to fall in the cabinet through ventilation slits to prevent component or circuit failures, or even dangerous fire hazard.
- The cabinet is provided with many ventilation slits on its rear and bottom. Do not attempt to cover with cloth, pads, or any other materials which may interfere proper ventilation.
- High voltage bearing components are contained in the cabinet. Do not attempt to remove the rear cover for safety against possible shock hazard. Refer servicing to qualified service personnel.

## ON (POWER SWITCH)

Power can be clicked on by turning the switch knob clockwise.

## POWER INDICATOR

Red indicator lamp will light up when power switch is turned on.

## CONTRAST

Adjust this control to obtain the proper contrast between the black and white portions of the displayed data.

## BRIGHTNESS

Determines the brilliance of the displayed data and is adjusted in conjunction with the Contrast control.

## VERTICAL HOLD

Stops any up or down movement of the displayed data. See the right figure.

## HORIZONTAL HOLD

Corrects any slanting of the displayed data. See the right figure.

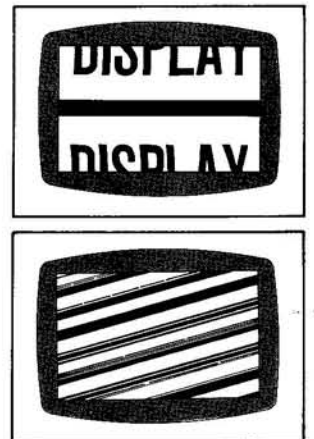

## VIDEO INPUT connector

As shown in the figure, the signal input cable from the computer is connected to the signal input connector.

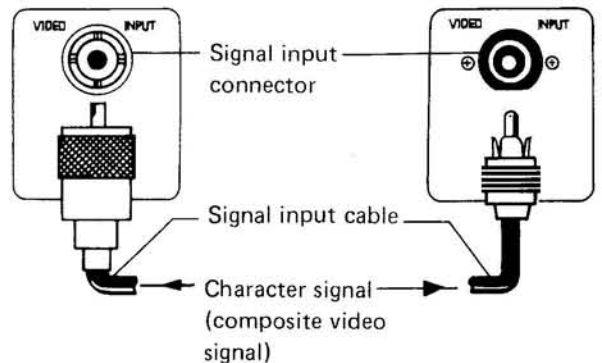

# SCHEMATIC DIAGRAM

**NOTE:**

1. This is a fundamental circuit diagram. Some production changes may be made without revision of the diagram.
2. All resistance values in ohm. K = 1,000 M = 1,000,000
3. Unless otherwise noted in schematic diagram, all capacitors less than 1 are expressed in mfd ( $\mu$ F) and the values larger than 1 are in pF.
4. Voltage reading taken with High Impedance Voltmeter from point indicated to chassis

5. All waveforms measured with strong signal input, contrast set to give normal picture.
6. Voltage reading may vary  $\pm 20\%$ .

